

N924 FFG

General Features

- Servo Drive Feeder
- High Speed Vacuum-Belt (VB) Feeding
- One-Touch Quick Ink recycling and washing
- Inner Chamber Multi-point washing sprays
- Plate Mounting Angle Correction
- Reinforced Scoring Slotting Unit
- Servo-Driven Rotary Die-cutter
- Auto Anvil Detach Function
- Auto Oscillating Mode for Anvil Cylinder
- Anvil Speed Control adjustment
- Medium Wave Infrared Dryer

Specifications

Speed:	320 s/m; 19200 s/hr
Corrugated board:	1~9 mm
Sheet Width:	270~850 mm
Total sheet length:	700~2500 mm
Printing Width:	850 mm
Printing Length:	2400 mm
Joint tab width:	45 mm
Large panel A:	220 mm
Small panel B:	80 mm
Folded length C (A+B):	350 mm (min)

Optional

- Auto RDC Anvil Grinder
- One touch Auto opening-up function for all or selected machine units
- Crush-free VB feeder (Release in Q4 2019)
- Dual-purpose Stacking

Electrical Power

Voltage:	380 V 50Hz, 3PH 280A
Power:	approx. 106 kW

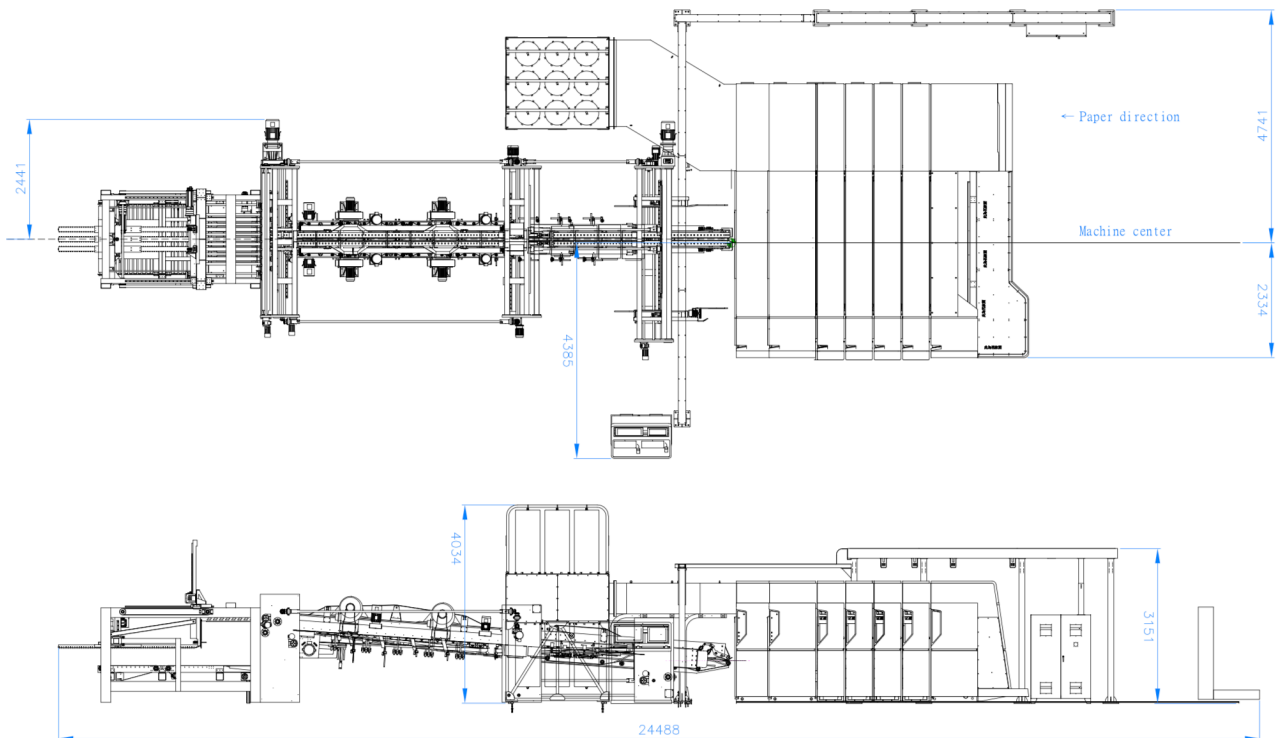

UNIT:mm



No.67 Guangdong Road, Pingzhen District, Taoyuan City, Taiwan
Tel: 886-3-4911180
email: info@blmagpie.com
website: www.blmagpie.com